

Image Processing I



CS180: Intro to Comp. Vision, and Comp. Photo
Alexei Efros & Angjoo Kanazawa, UC Berkeley, Fall 2023

What is an image?

We can think of an **image** as a function, f , from \mathbb{R}^2 to \mathbb{R} :

- $f(x, y)$ gives the **intensity** at position (x, y)
- Realistically, we expect the image only to be defined over a rectangle, with a finite range:
 - $f: [a,b] \times [c,d] \rightarrow [0,1]$

A color image is just three functions pasted together.
We can write this as a “vector-valued” function:

$$f(x, y) = \begin{bmatrix} r(x, y) \\ g(x, y) \\ b(x, y) \end{bmatrix}$$

Images as functions

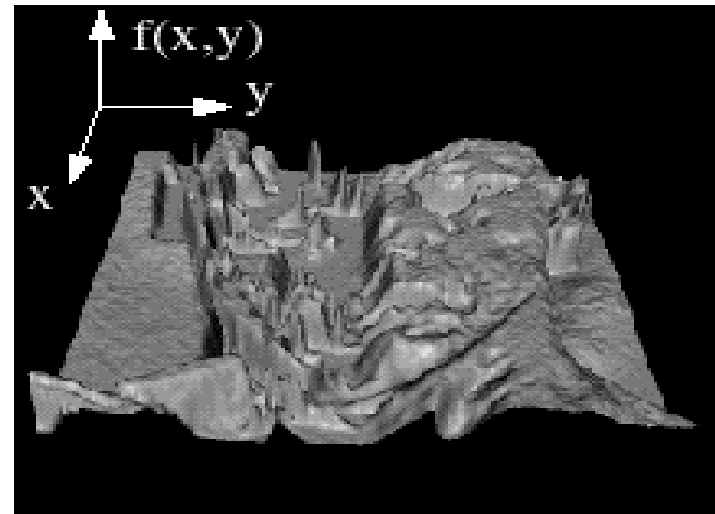
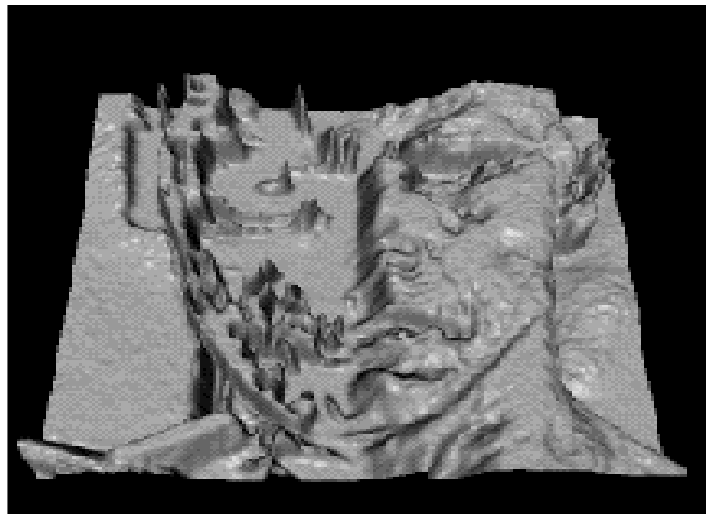

Image Formation

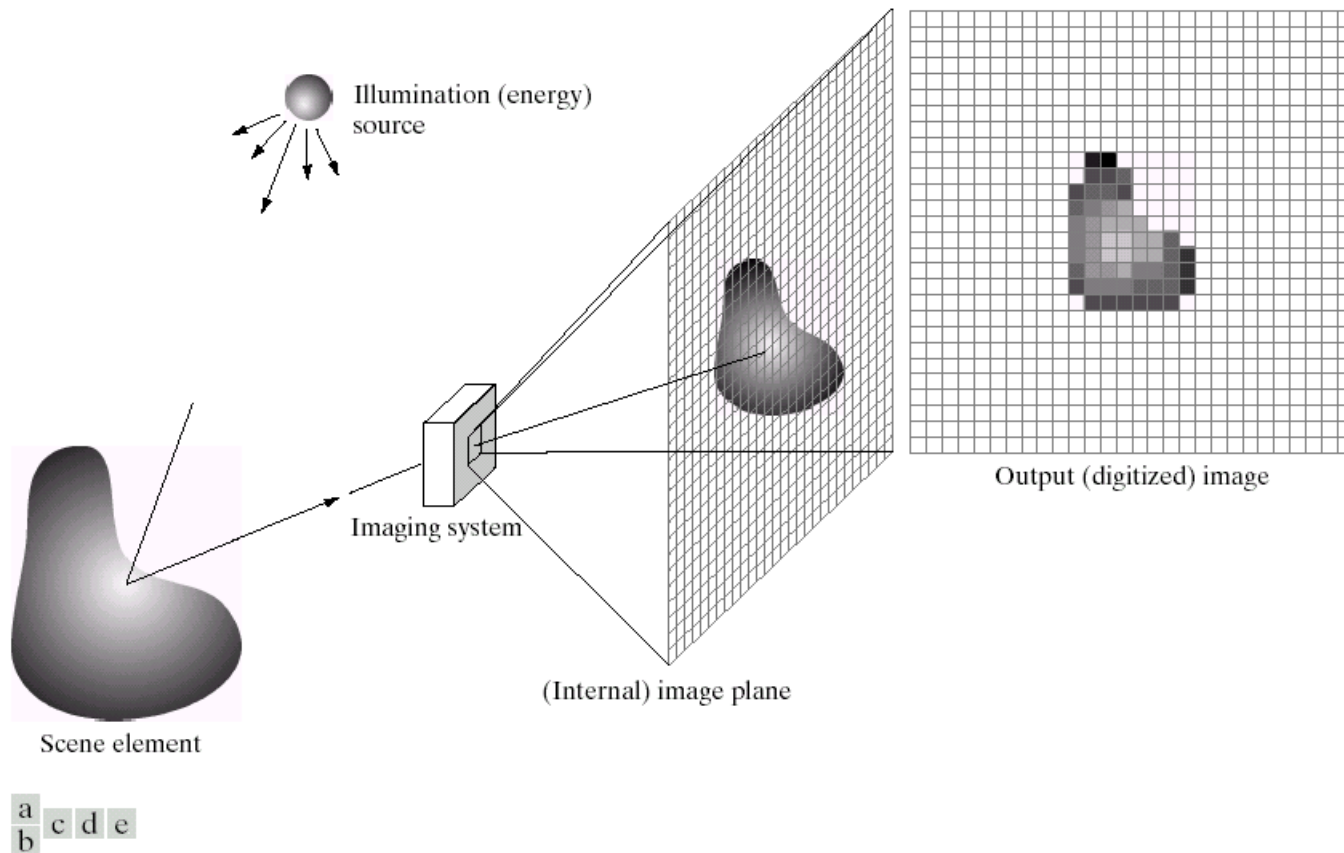

FIGURE 2.15 An example of the digital image acquisition process. (a) Energy (“illumination”) source. (b) An element of a scene. (c) Imaging system. (d) Projection of the scene onto the image plane. (e) Digitized image.

$$f(x,y) = \text{reflectance}(x,y) * \text{illumination}(x,y)$$

Reflectance in $[0, 1]$, illumination in $[0, \text{inf}]$

Problem: Dynamic Range

The real world is
High dynamic range

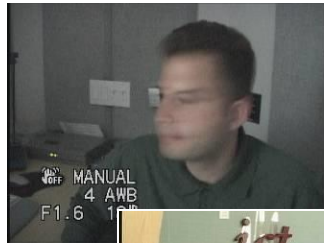

1



1500



25,000



400,000



2,000,000,000

Long Exposure

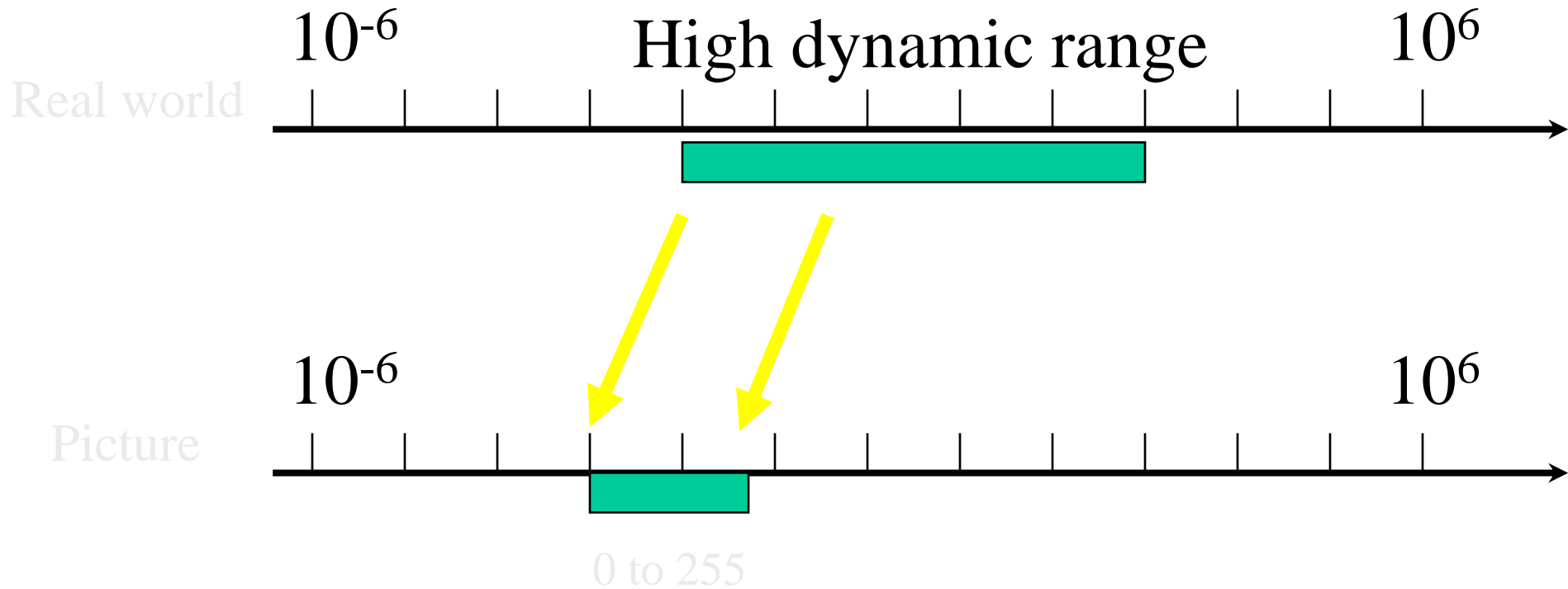

Short Exposure

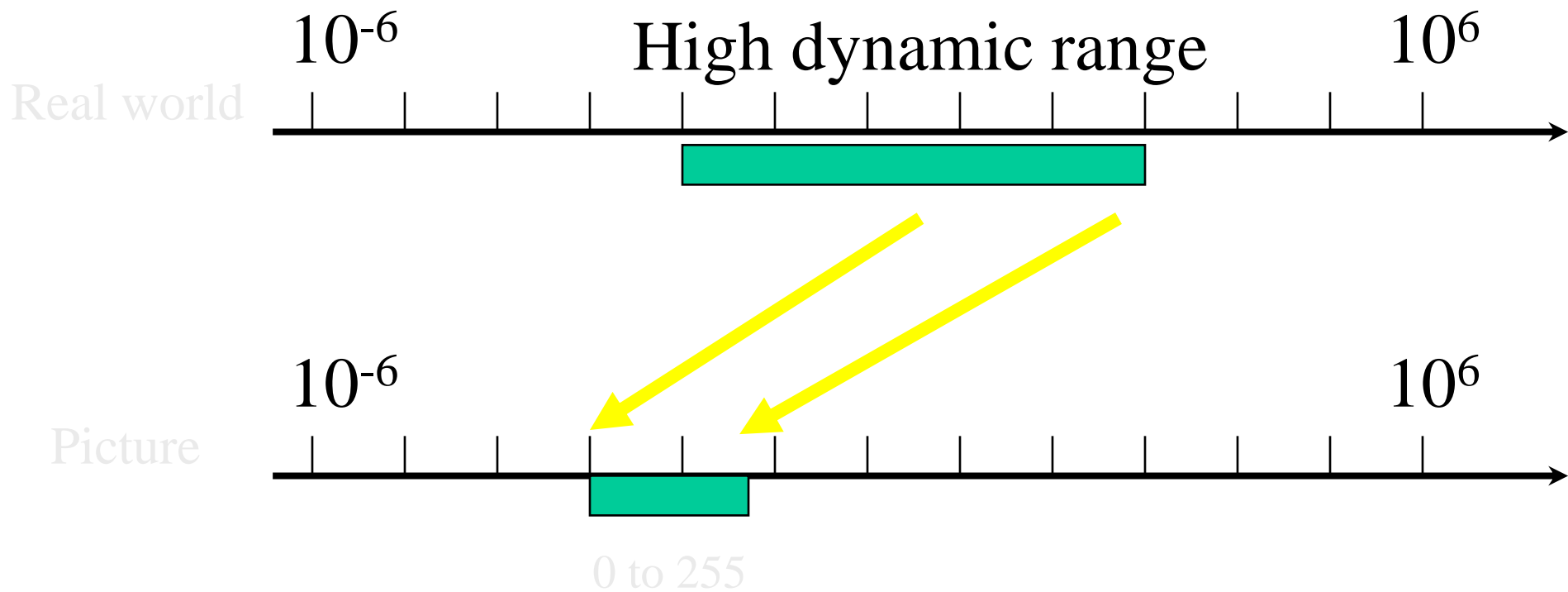
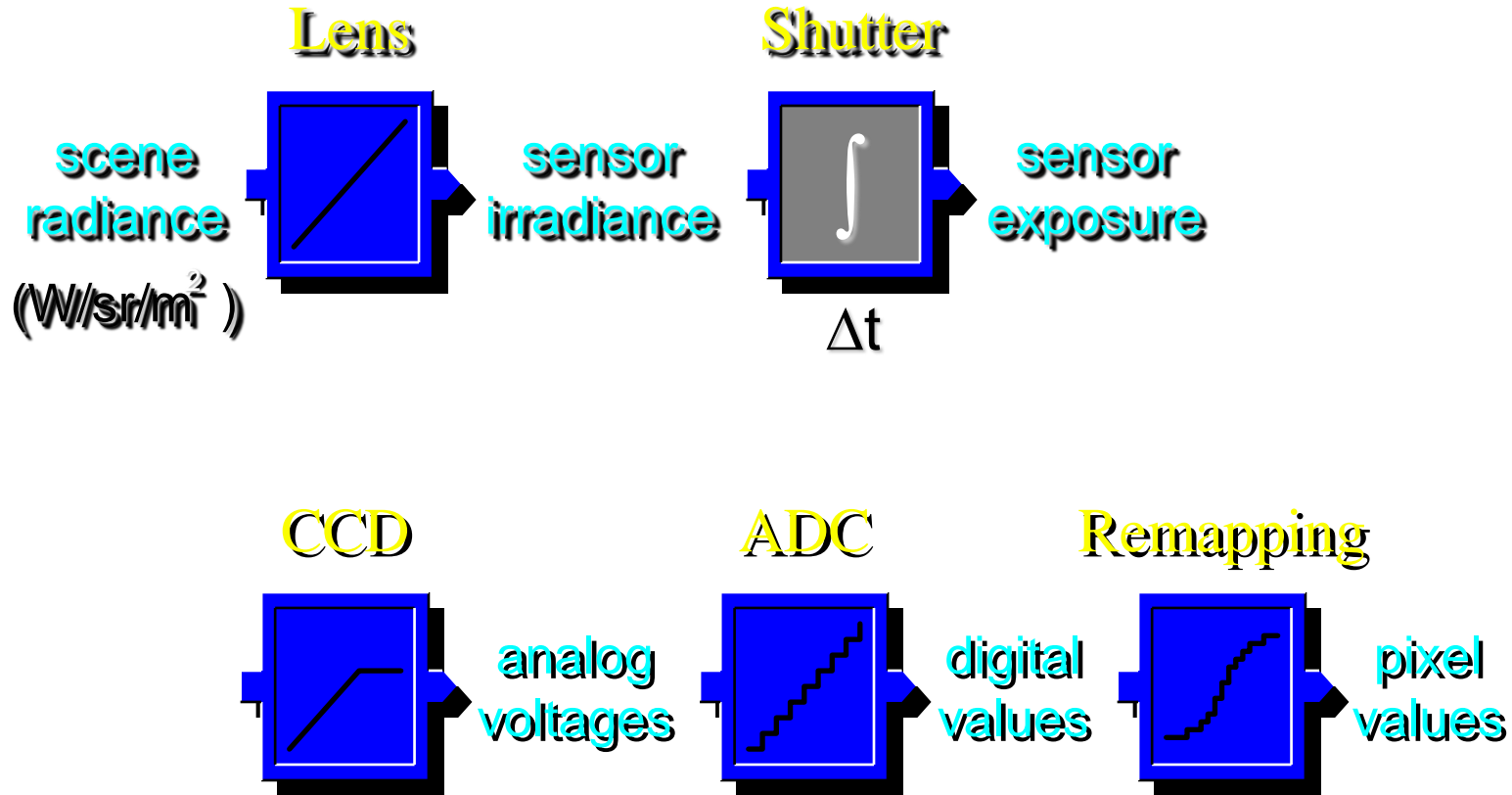

Image Acquisition Pipeline



Simple Point Processing: Enhancement

a b
c d

FIGURE 3.9

(a) Aerial image.
(b)–(d) Results of applying the transformation in Eq. (3.2-3) with $c = 1$ and $\gamma = 3.0, 4.0,$ and 5.0 , respectively. (Original image for this example courtesy of NASA.)



Power-law transformations

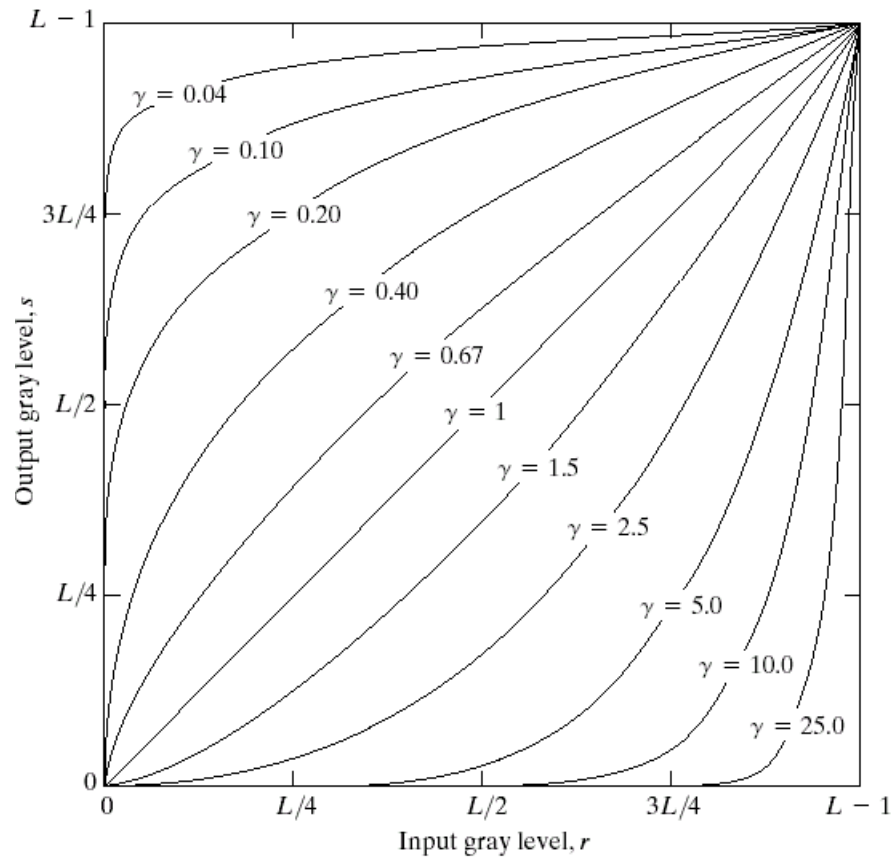
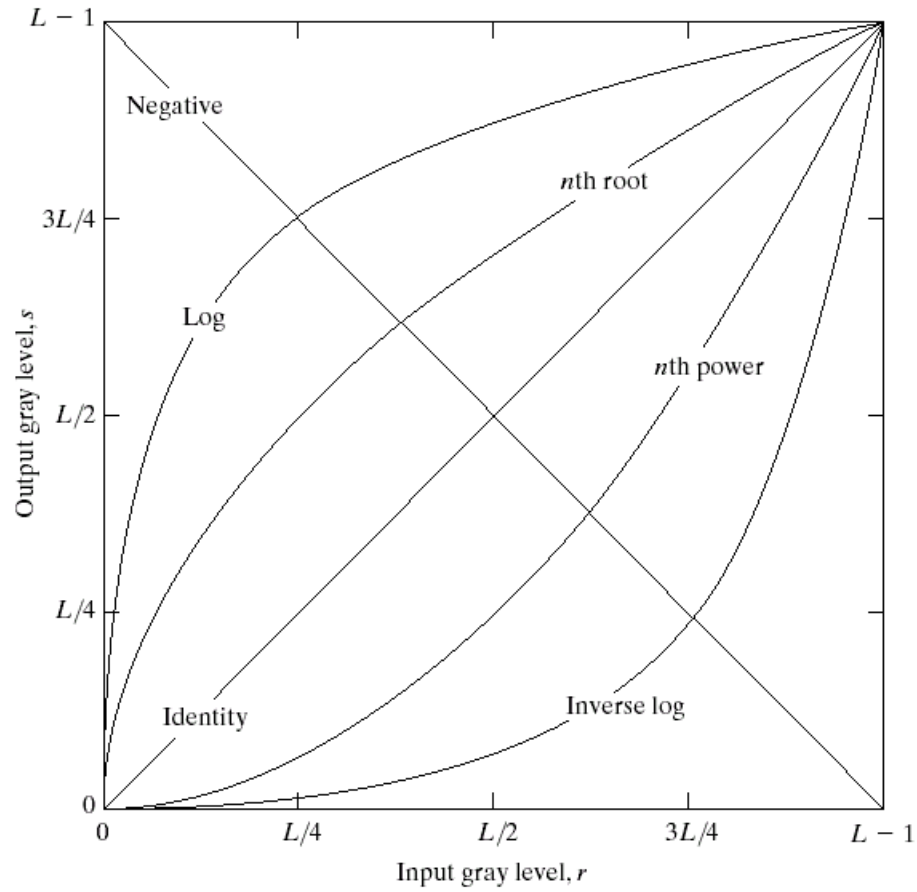

FIGURE 3.6 Plots of the equation $s = cr^\gamma$ for various values of γ ($c = 1$ in all cases).

$$s = cr^\gamma$$

Basic Point Processing

FIGURE 3.3 Some basic gray-level transformation functions used for image enhancement.



Negative

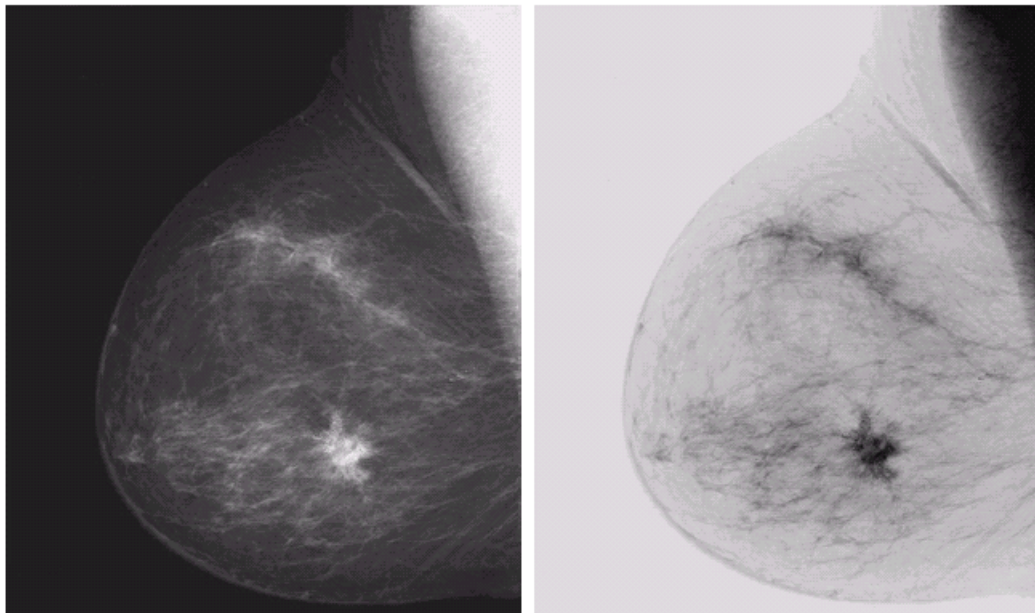

a b

FIGURE 3.4

(a) Original digital mammogram.
(b) Negative image obtained using the negative transformation in Eq. (3.2-1).
(Courtesy of G.E. Medical Systems.)

Log

a b

FIGURE 3.5

(a) Fourier spectrum.

(b) Result of applying the log transformation given in Eq. (3.2-2) with $c = 1$.

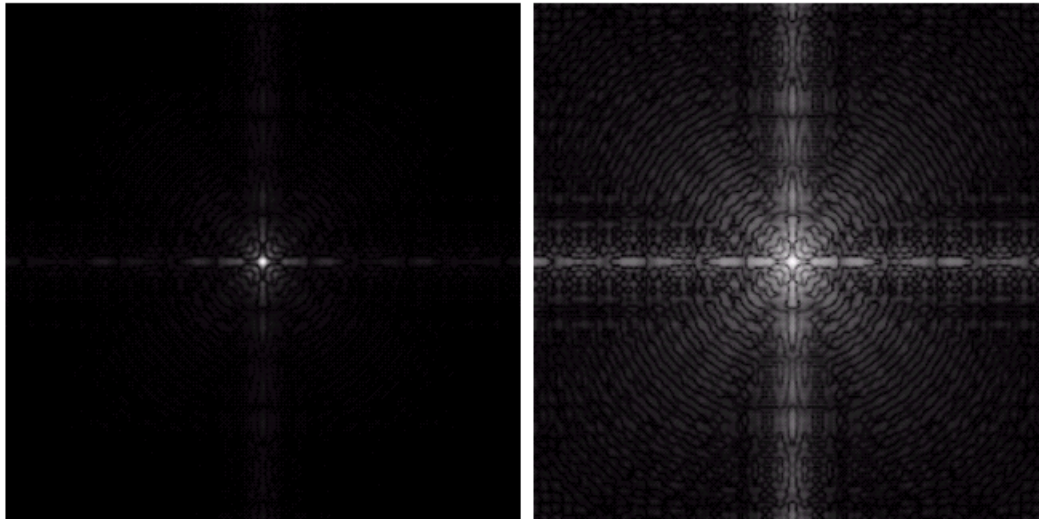

Contrast Stretching

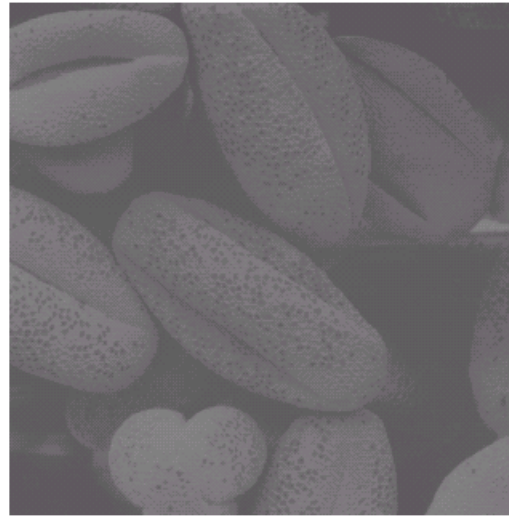
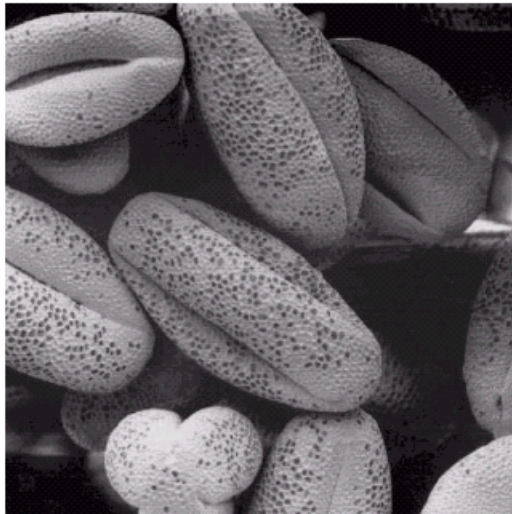
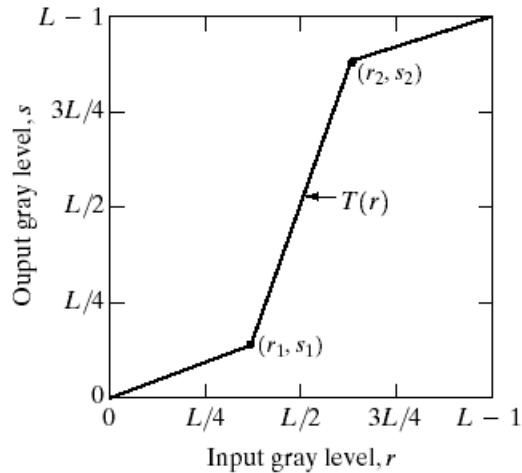

a b
c d

FIGURE 3.10

Contrast stretching. (a) Form of transformation function. (b) A low-contrast image. (c) Result of contrast stretching. (d) Result of thresholding. (Original image courtesy of Dr. Roger Heady, Research School of Biological Sciences, Australian National University, Canberra, Australia.)

Image Histograms

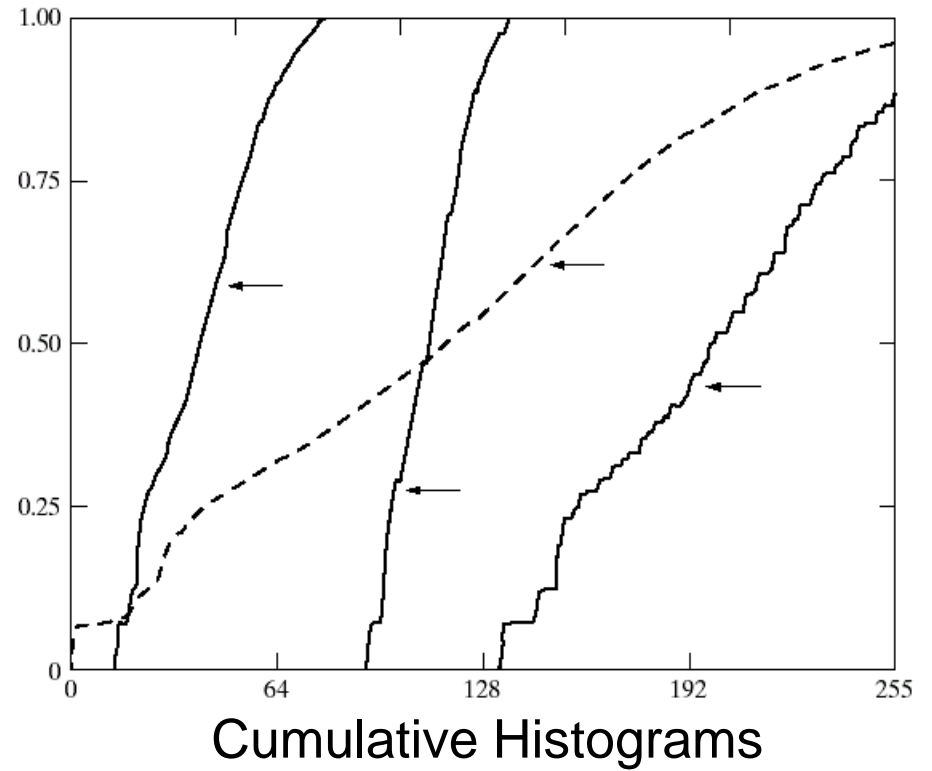
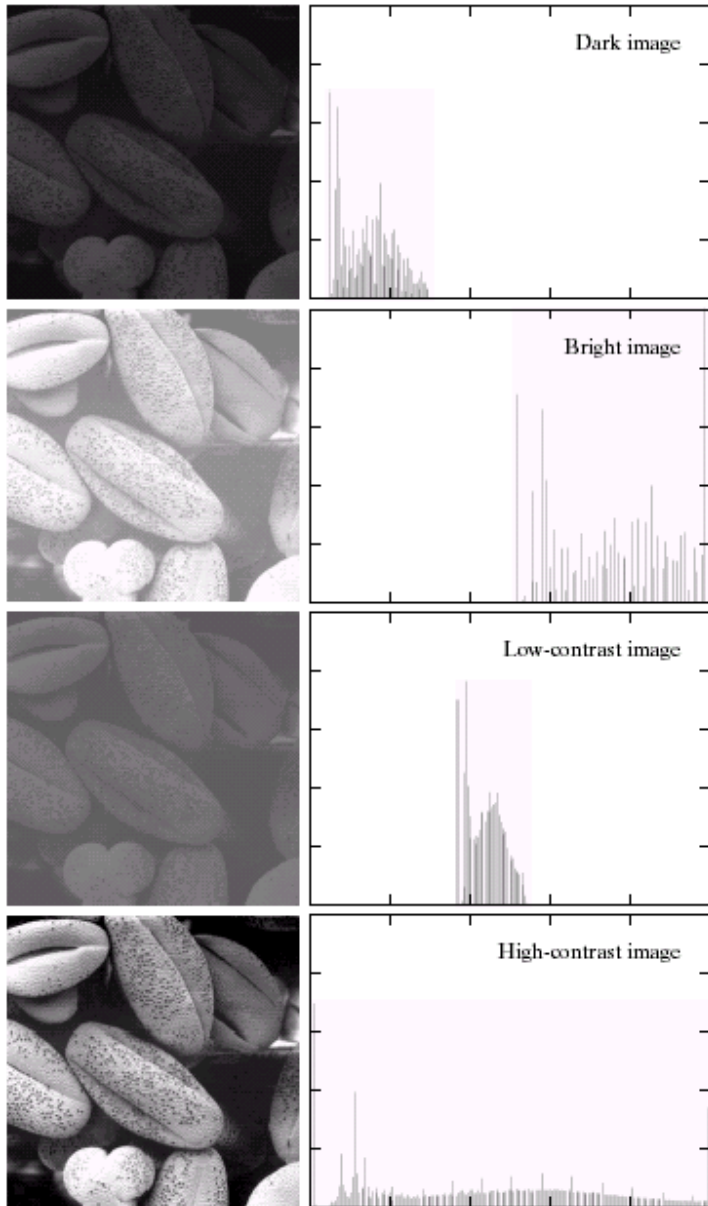

$$s = T(r)$$

a b

FIGURE 3.15 Four basic image types: dark, light, low contrast, high contrast, and their corresponding histograms. (Original image courtesy of Dr. Roger Heady, Research School of Biological Sciences, Australian National University, Canberra, Australia.)

Histogram Equalization

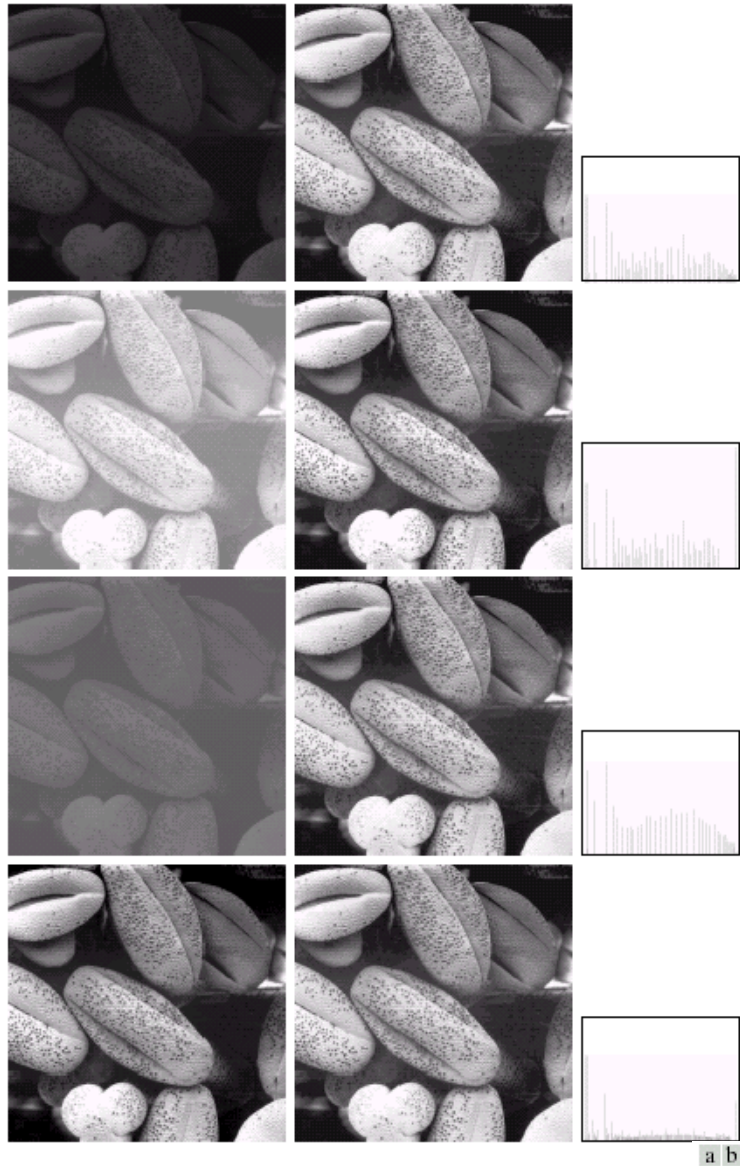

a b c

FIGURE 3.17 (a) Images from Fig. 3.15. (b) Results of histogram equalization. (c) Corresponding histograms.

Color Transfer [Reinhard, et al, 2001]

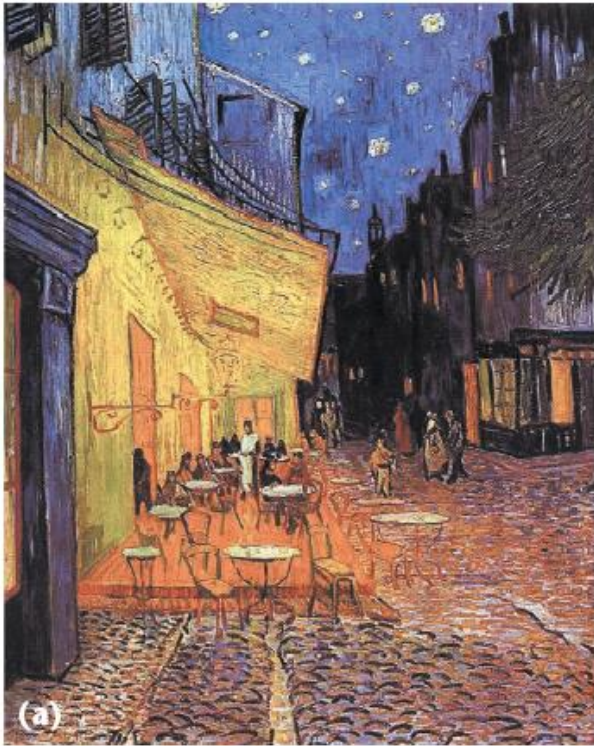

Limitations of Point Processing...

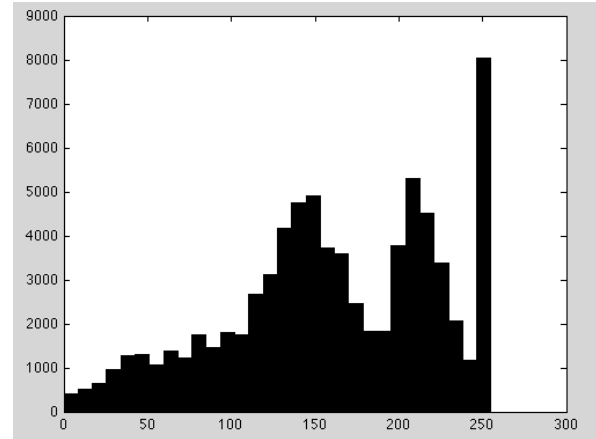
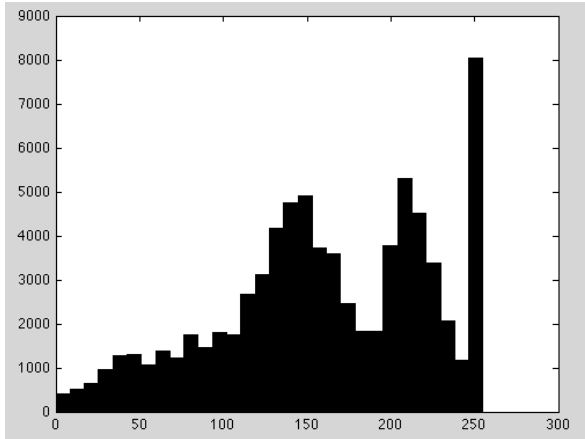
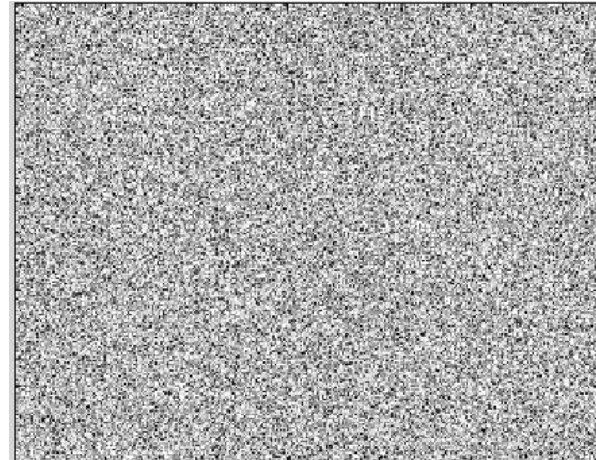

Sampling and Reconstruction

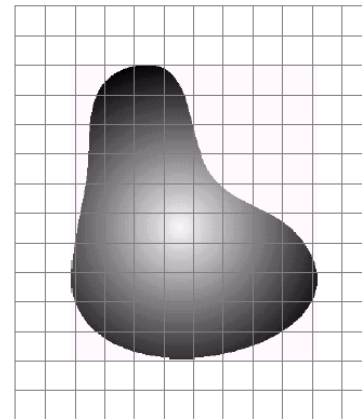
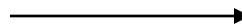
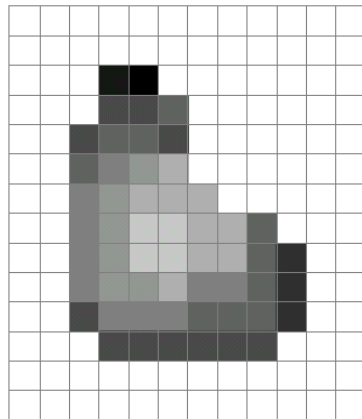
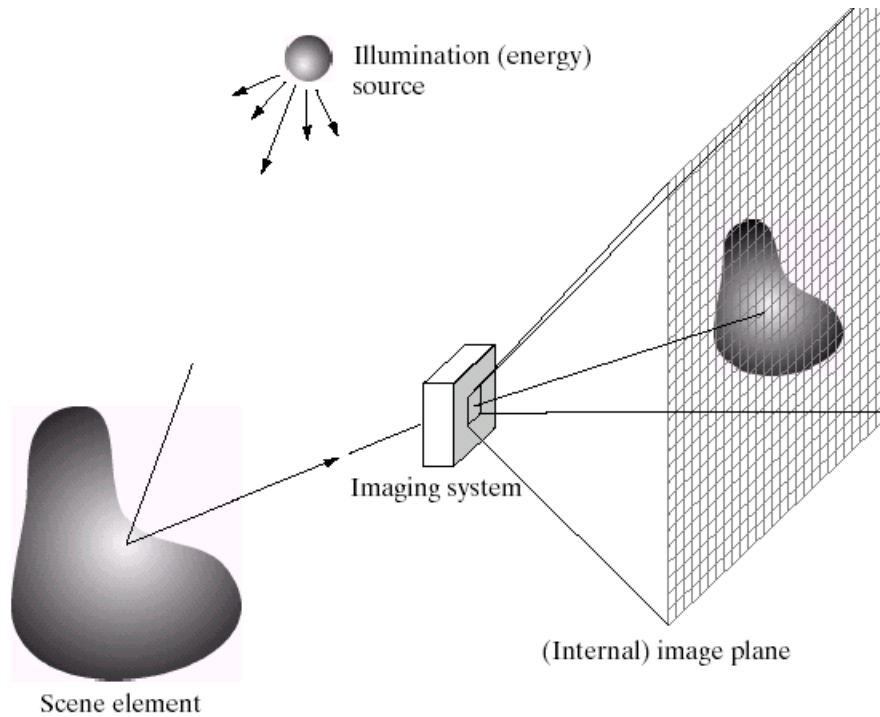

Sampled representations

- How to store and compute with continuous functions?
- Common scheme for representation: samples
 - write down the function's values at many points

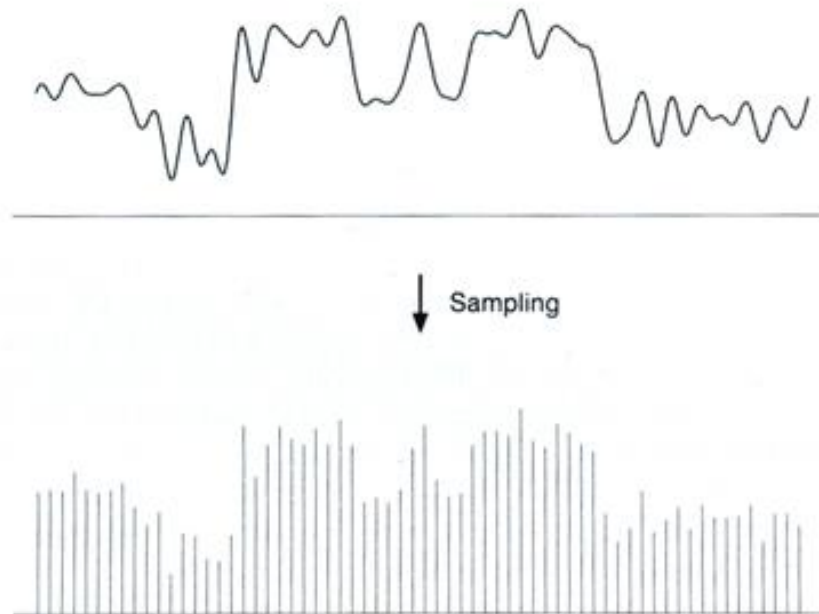

Reconstruction

- Making samples back into a continuous function
 - for output (need realizable method)
 - for analysis or processing (need mathematical method)
 - amounts to “guessing” what the function did in between

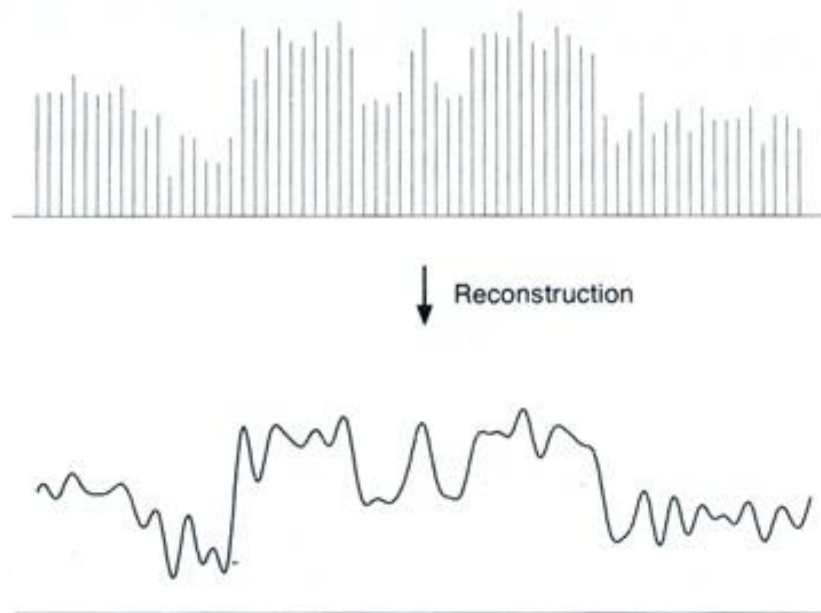

1D Example: Audio

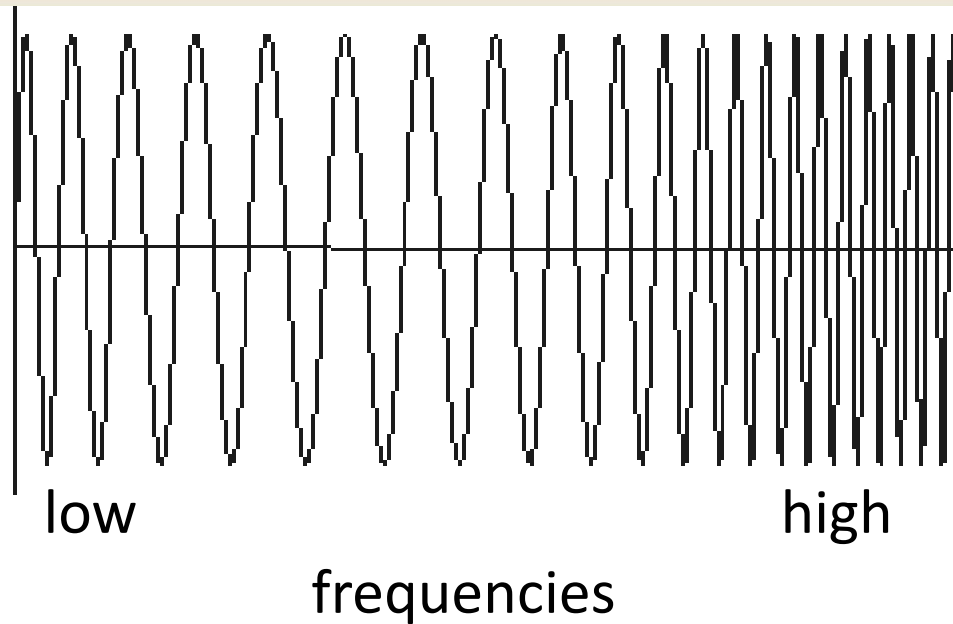
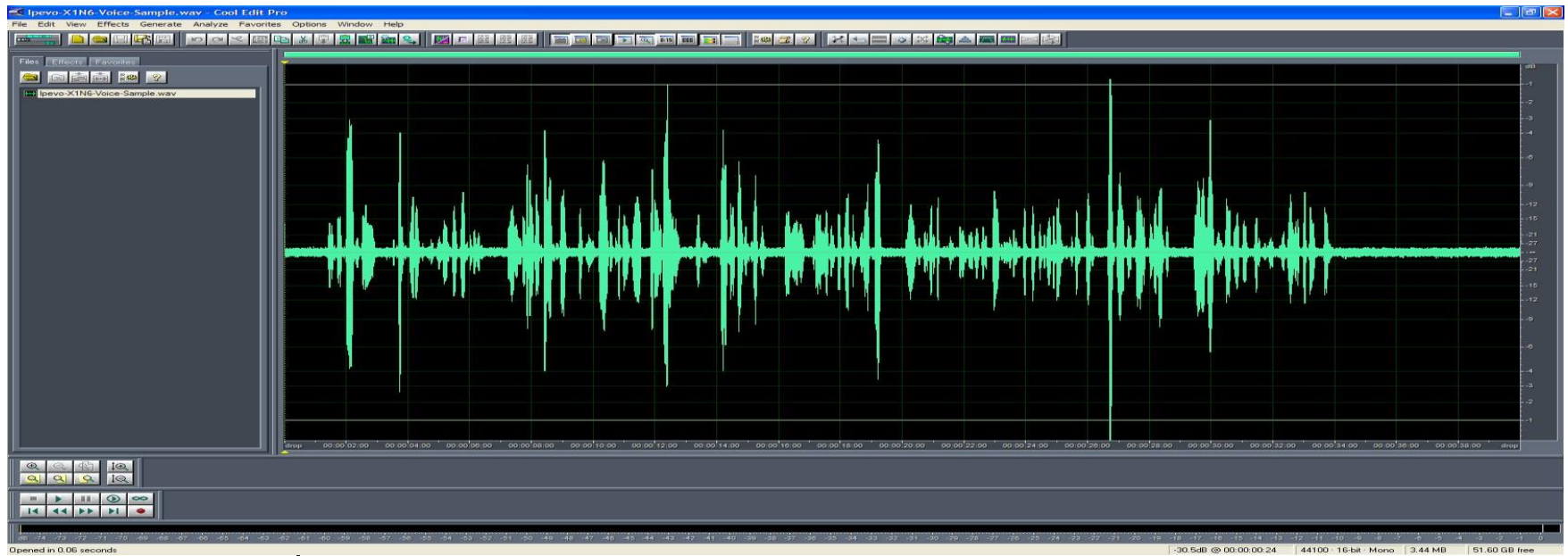

Sampling in digital audio

- Recording: sound to analog to samples to disc
- Playback: disc to samples to analog to sound again
 - how can we be sure we are filling in the gaps correctly?

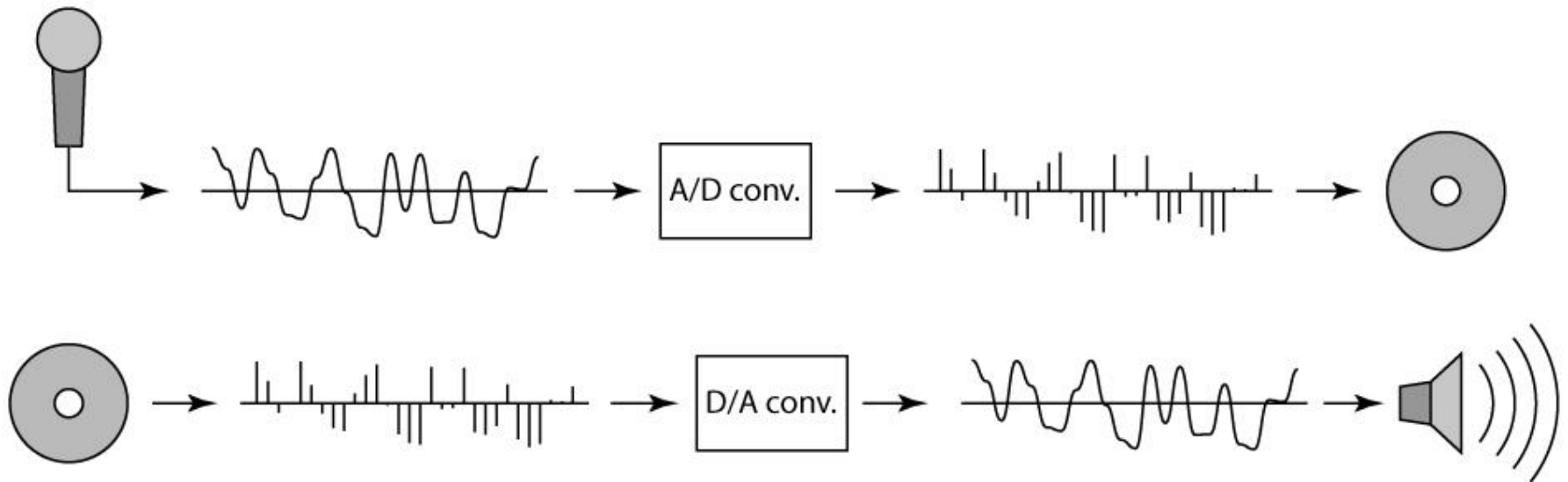

Sampling and Reconstruction

- Simple example: a sign wave

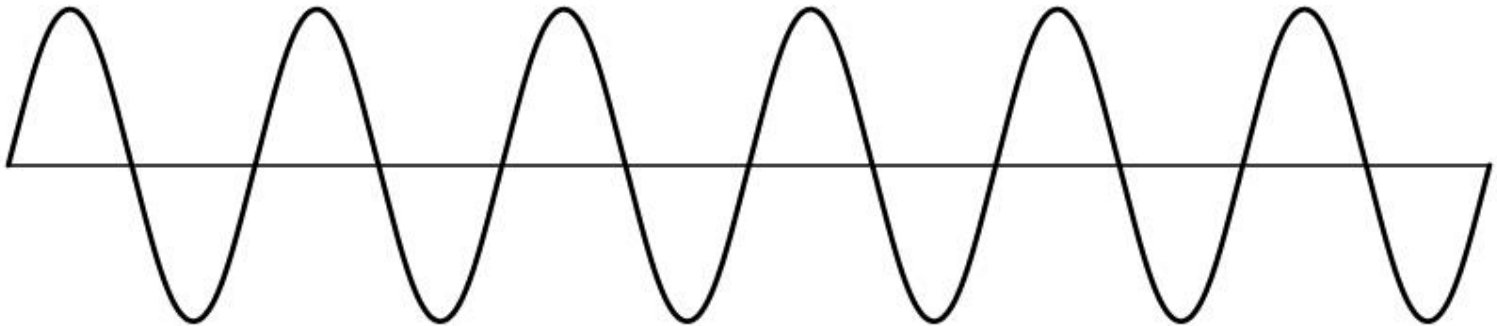

Undersampling

- What if we “missed” things between the samples?
- Simple example: undersampling a sine wave
 - unsurprising result: information is lost

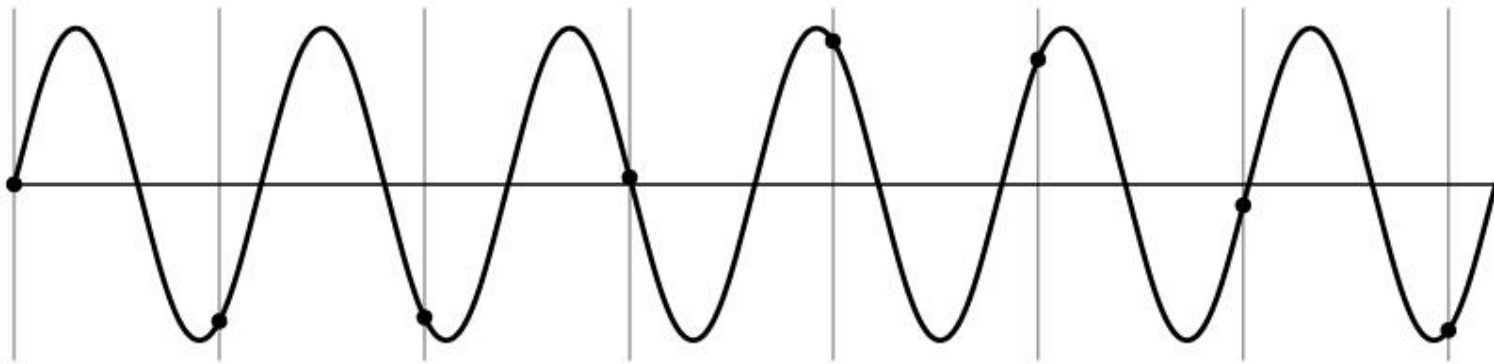

Undersampling

- What if we “missed” things between the samples?
- Simple example: undersampling a sine wave
 - unsurprising result: information is lost
 - surprising result: indistinguishable from lower frequency

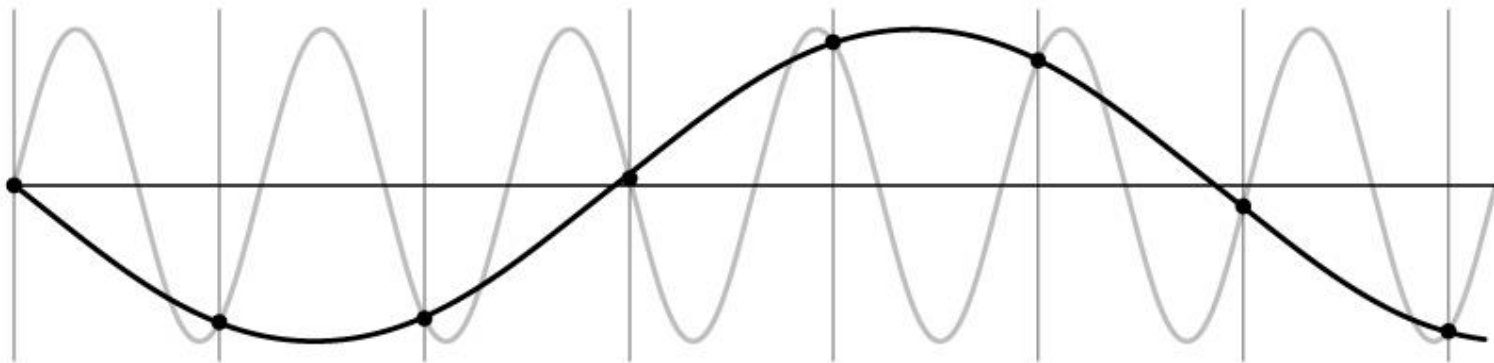

Undersampling

- What if we “missed” things between the samples?
- Simple example: undersampling a sine wave
 - unsurprising result: information is lost
 - surprising result: indistinguishable from lower frequency
 - also, was always indistinguishable from higher frequencies
 - aliasing: signals “traveling in disguise” as other frequencies

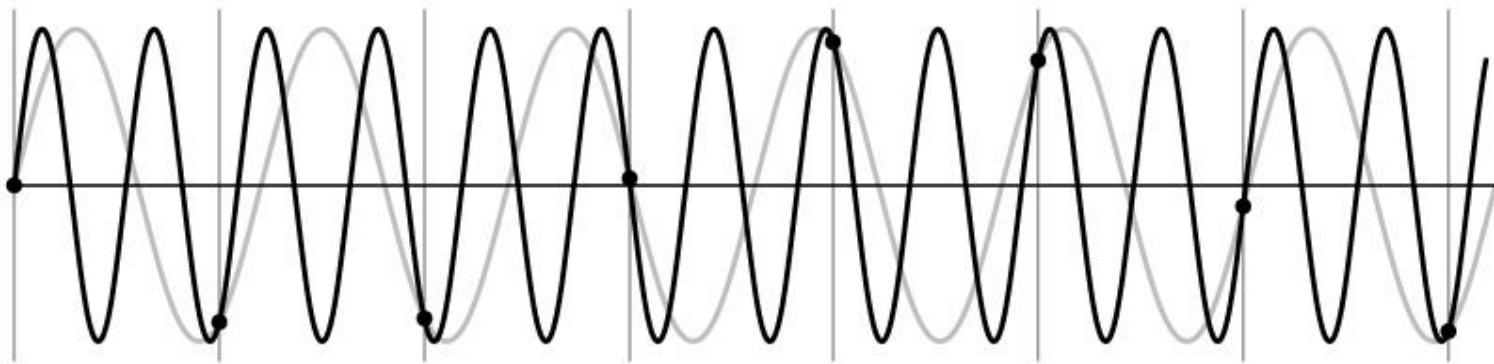

Aliasing in video

Imagine a spoked wheel moving to the right (rotating clockwise).

Mark wheel with dot so we can see what's happening.

If camera shutter is only open for a fraction of a frame time (frame time = 1/30 sec. for video, 1/24 sec. for film):

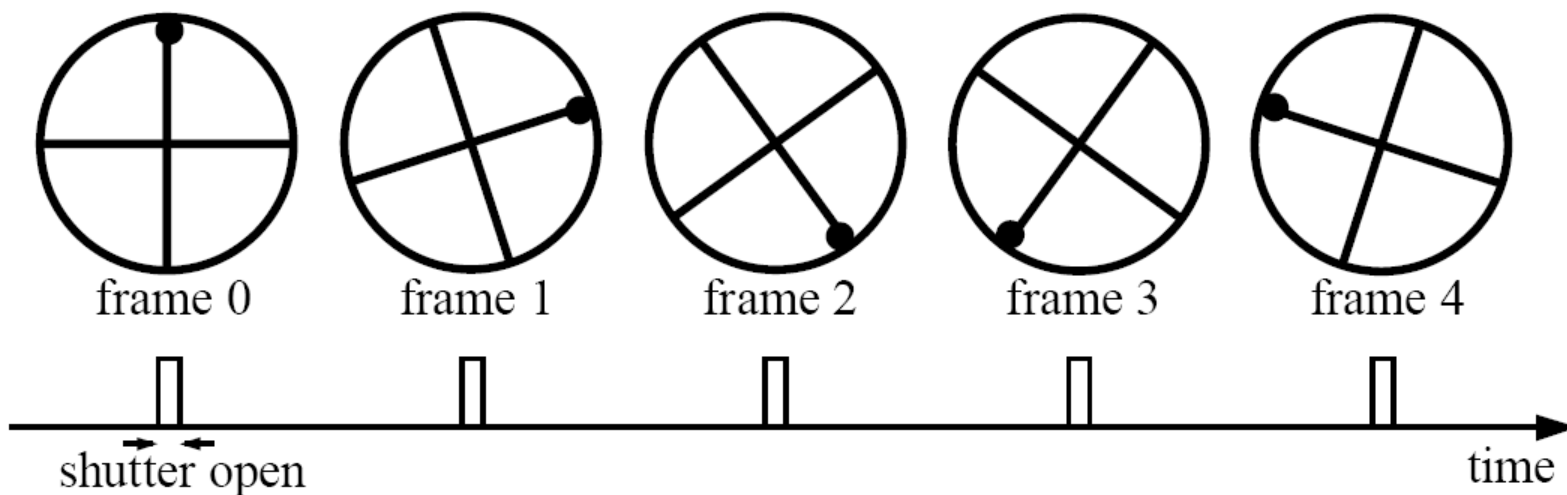

Without dot, wheel appears to be rotating slowly backwards!
(counterclockwise)



TEACH ME
www.teachme.com

Aliasing in images

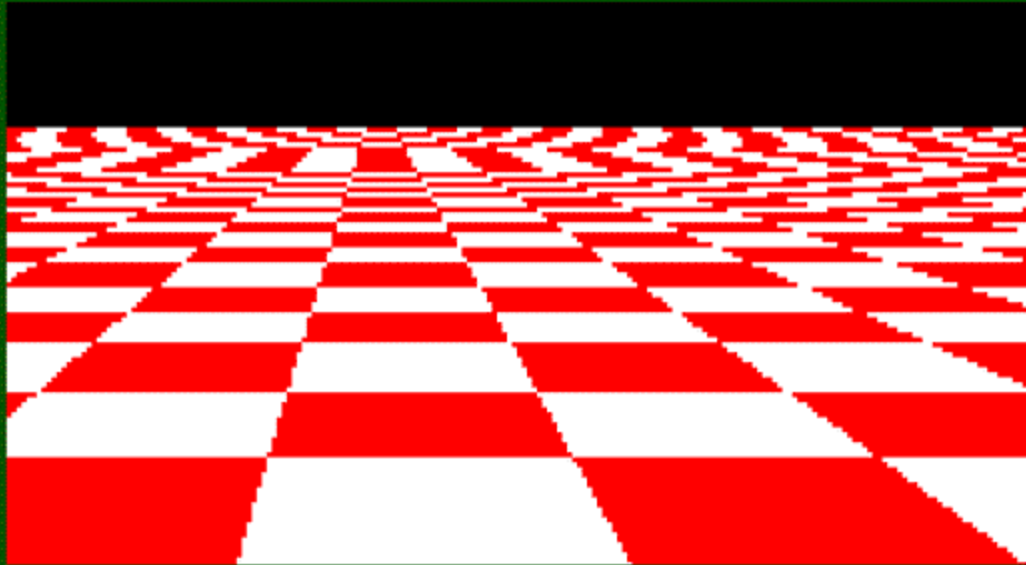

Disintegrating textures

Aliasing in real images



What's happening?

Input signal:

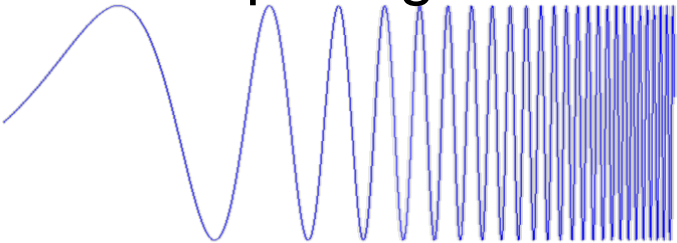

Plot as image:

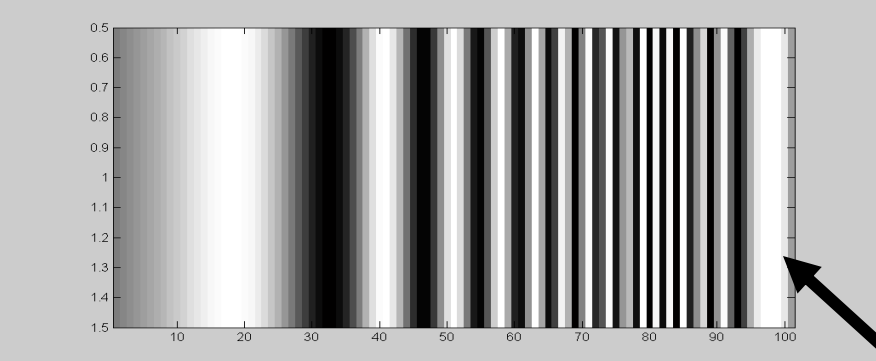

```
x = 0:.05:5; imagesc(sin((2.^x).*x))
```

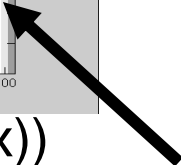

Alias!

Not enough samples

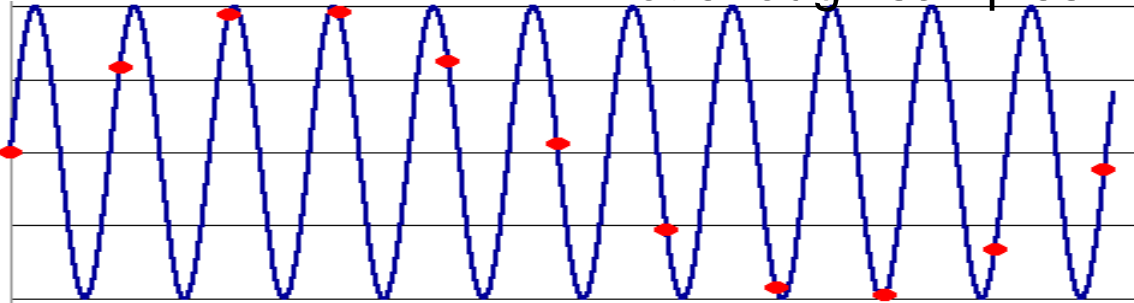

Antialiasing

What can we do about aliasing?

Sample more often

- Join the Mega-Pixel craze of the photo industry
- But this can't go on forever

Make the signal less “wiggly”

- Get rid of some high frequencies
- Will lose information
- But it's better than aliasing

Preventing aliasing

- Introduce lowpass filters:
 - remove high frequencies leaving only safe, low frequencies
 - choose lowest frequency in reconstruction (disambiguate)

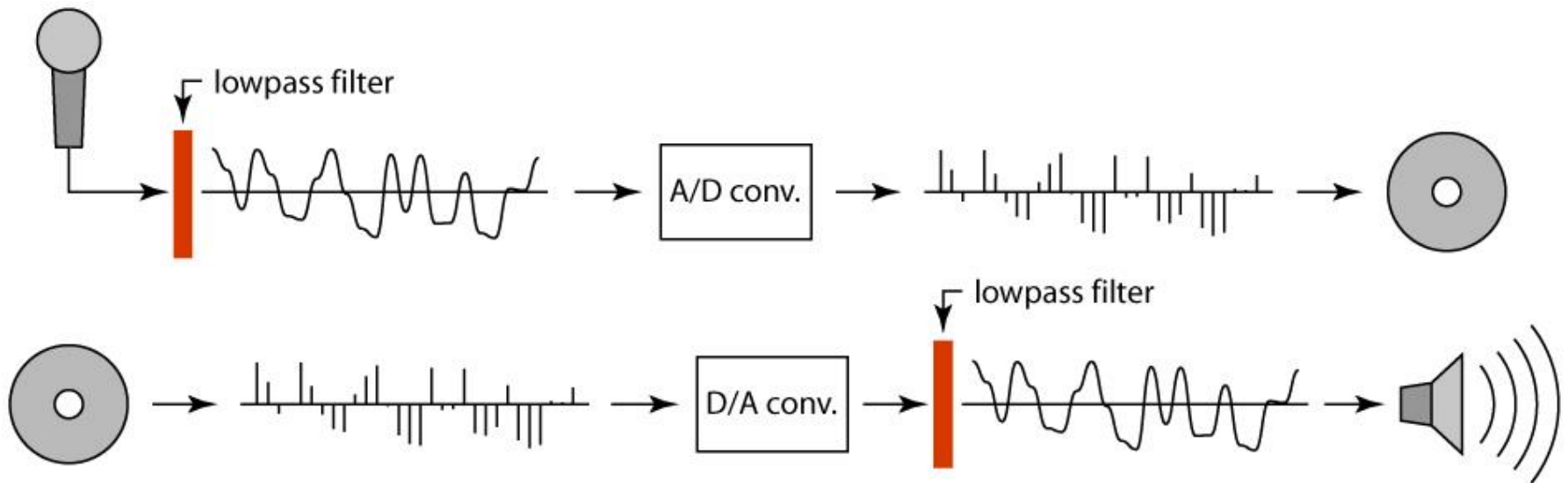

Linear filtering: a key idea

- Transformations on signals; e.g.:
 - bass/treble controls on stereo
 - blurring/sharpening operations in image editing
 - smoothing/noise reduction in tracking
- Key properties
 - linearity: $\text{filter}(f + g) = \text{filter}(f) + \text{filter}(g)$
 - shift invariance: behavior invariant to shifting the input
 - delaying an audio signal
 - sliding an image around
- Can be modeled mathematically by *convolution*

Moving Average

- basic idea: define a new function by averaging over a sliding window
- a simple example to start off: smoothing

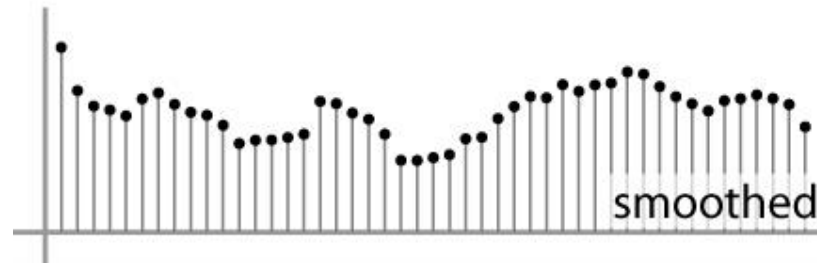
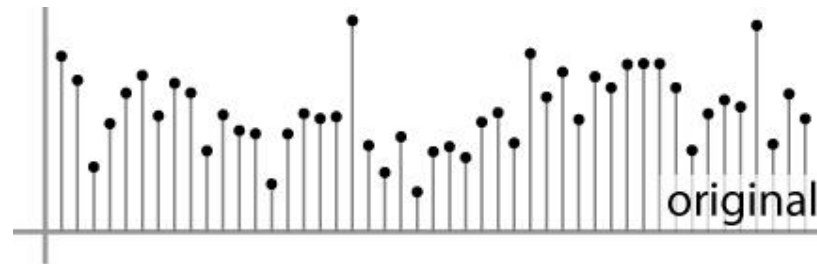

Moving Average

- Can add weights to our moving average
- *Weights* [..., 0, 1, 1, 1, 1, 1, 0, ...] / 5

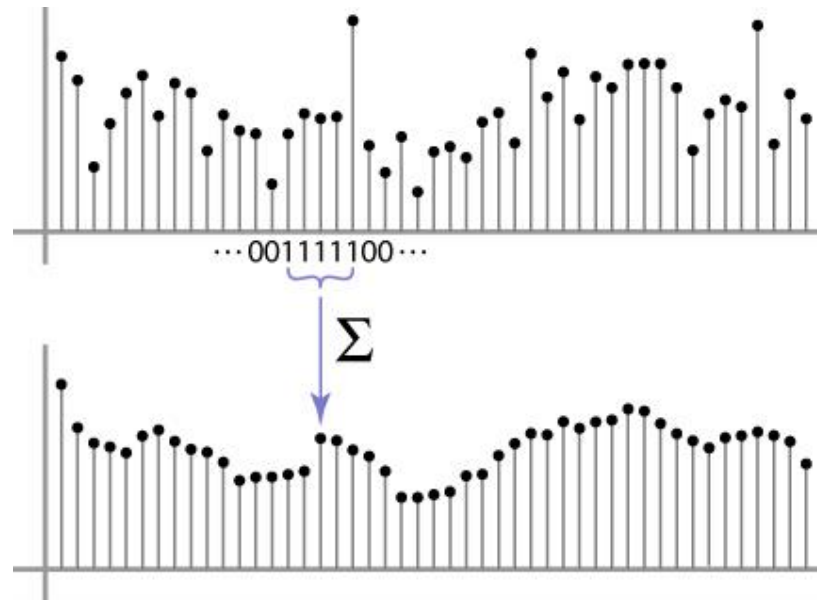

In 2D: box filter

$h[\cdot, \cdot]$

$\frac{1}{9}$	1	1	1
	1	1	1
	1	1	1

Image filtering

$$h[\cdot, \cdot] \frac{1}{9} \begin{array}{|c|c|c|} \hline 1 & 1 & 1 \\ \hline 1 & 1 & 1 \\ \hline 1 & 1 & 1 \\ \hline \end{array}$$

$f[\cdot, \cdot]$

0	0	0	0	0	0	0	0	0	0	0
0	0	0	0	0	0	0	0	0	0	0
0	0	0	90	90	90	90	90	0	0	0
0	0	0	90	90	90	90	90	0	0	0
0	0	0	90	90	90	90	90	0	0	0
0	0	0	90	0	90	90	90	0	0	0
0	0	0	90	90	90	90	90	0	0	0
0	0	0	0	0	0	0	0	0	0	0
0	0	90	0	0	0	0	0	0	0	0
0	0	0	0	0	0	0	0	0	0	0

$g[\cdot, \cdot]$

$$g[m, n] = \sum_{k, l} h[k, l] f[m+k, n+l]$$

Image filtering

$$h[\cdot, \cdot] \frac{1}{9}$$

1	1	1
1	1	1
1	1	1

$f[\cdot, \cdot]$

0	0	0	0	0	0	0	0	0	0
0	0	0	0	0	0	0	0	0	0
0	0	0	90	90	90	90	90	0	0
0	0	0	90	90	90	90	90	0	0
0	0	0	90	90	90	90	90	0	0
0	0	0	90	0	90	90	90	0	0
0	0	0	90	90	90	90	90	0	0
0	0	0	0	0	0	0	0	0	0
0	0	90	0	0	0	0	0	0	0
0	0	0	0	0	0	0	0	0	0

$g[\cdot, \cdot]$

	0	10							

$$g[m, n] = \sum_{k, l} h[k, l] f[m+k, n+l]$$

Image filtering

$$h[\cdot, \cdot] \frac{1}{9}$$

1	1	1
1	1	1
1	1	1

$f[\cdot, \cdot]$

0	0	0	0	0	0	0	0	0	0
0	0	0	0	0	0	0	0	0	0
0	0	0	90	90	90	90	90	0	0
0	0	0	90	90	90	90	90	0	0
0	0	0	90	90	90	90	90	0	0
0	0	0	90	0	90	90	90	0	0
0	0	0	90	90	90	90	90	0	0
0	0	0	0	0	0	0	0	0	0
0	0	90	0	0	0	0	0	0	0
0	0	0	0	0	0	0	0	0	0

$g[\cdot, \cdot]$

	0	10	20						

Image filtering

$$h[\cdot, \cdot] \frac{1}{9}$$

1	1	1
1	1	1
1	1	1

$f[\cdot, \cdot]$

0	0	0	0	0	0	0	0	0	0
0	0	0	0	0	0	0	0	0	0
0	0	0	90	90	90	90	90	0	0
0	0	0	90	90	90	90	90	0	0
0	0	0	90	90	90	90	90	0	0
0	0	0	90	0	90	90	90	0	0
0	0	0	90	90	90	90	90	0	0
0	0	0	0	0	0	0	0	0	0
0	0	90	0	0	0	0	0	0	0
0	0	0	0	0	0	0	0	0	0

$g[\cdot, \cdot]$

	0	10	20	30					

Image filtering

$$h[\cdot, \cdot] \frac{1}{9}$$

1	1	1
1	1	1
1	1	1

$f[\cdot, \cdot]$

0	0	0	0	0	0	0	0	0	0
0	0	0	0	0	0	0	0	0	0
0	0	0	90	90	90	90	90	0	0
0	0	0	90	90	90	90	90	0	0
0	0	0	90	90	90	90	90	0	0
0	0	0	90	0	90	90	90	0	0
0	0	0	90	90	90	90	90	0	0
0	0	0	0	0	0	0	0	0	0
0	0	90	0	0	0	0	0	0	0
0	0	0	0	0	0	0	0	0	0

$g[\cdot, \cdot]$

	0	10	20	30	30				

Image filtering

$$h[\cdot, \cdot] \frac{1}{9} \begin{array}{|c|c|c|} \hline 1 & 1 & 1 \\ \hline 1 & 1 & 1 \\ \hline 1 & 1 & 1 \\ \hline \end{array}$$

$$f[\cdot, \cdot]$$

0	0	0	0	0	0	0	0	0	0
0	0	0	0	0	0	0	0	0	0
0	0	0	90	90	90	90	90	0	0
0	0	0	90	90	90	90	90	0	0
0	0	0	90	90	90	90	90	0	0
0	0	0	90	0	90	90	90	0	0
0	0	0	90	90	90	90	90	0	0
0	0	0	0	0	0	0	0	0	0
0	0	90	0	0	0	0	0	0	0
0	0	0	0	0	0	0	0	0	0

$$g[\cdot, \cdot]$$

	0	10	20	30	30				

?

Image filtering

$$h[\cdot, \cdot] \frac{1}{9}$$

1	1	1
1	1	1
1	1	1

$f[\cdot, \cdot]$

0	0	0	0	0	0	0	0	0	0
0	0	0	0	0	0	0	0	0	0
0	0	0	90	90	90	90	90	0	0
0	0	0	90	90	90	90	90	0	0
0	0	0	90	90	90	90	90	0	0
0	0	0	90	0	90	90	90	0	0
0	0	0	90	90	90	90	90	0	0
0	0	0	0	0	0	0	0	0	0
0	0	90	0	0	0	0	0	0	0
0	0	0	0	0	0	0	0	0	0

$g[\cdot, \cdot]$

	0	10	20	30	30				
						?			
				50					

Image filtering

$$h[\cdot, \cdot] \frac{1}{9} \begin{bmatrix} 1 & 1 & 1 \\ 1 & 1 & 1 \\ 1 & 1 & 1 \end{bmatrix}$$

$f[\cdot, \cdot]$

0	0	0	0	0	0	0	0	0	0
0	0	0	0	0	0	0	0	0	0
0	0	0	90	90	90	90	90	0	0
0	0	0	90	90	90	90	90	0	0
0	0	0	90	90	90	90	90	0	0
0	0	0	90	0	90	90	90	0	0
0	0	0	90	90	90	90	90	0	0
0	0	0	0	0	0	0	0	0	0
0	0	90	0	0	0	0	0	0	0
0	0	0	0	0	0	0	0	0	0

$g[\cdot, \cdot]$

	0	10	20	30	30	30	20	10	
	0	20	40	60	60	60	40	20	
	0	30	60	90	90	90	60	30	
	0	30	50	80	80	90	60	30	
	0	30	50	80	80	90	60	30	
	0	20	30	50	50	60	40	20	
	10	20	30	30	30	30	20	10	
	10	10	10	0	0	0	0	0	

Cross-correlation

Let F be the image, H be the kernel (of size $2k+1 \times 2k+1$), and G be the output image

$$G[i, j] = \sum_{u=-k}^k \sum_{v=-k}^k H[u, v] F[i + u, j + v]$$

This is called a **cross-correlation** operation:

$$G = H \otimes F$$

- Can think of as a “dot product” between local neighborhood and kernel for each pixel

Box Filter

What does it do?

- Replaces each pixel with an average of its neighborhood
- Achieve smoothing effect (remove sharp features)

$$\frac{1}{9} h[\cdot, \cdot]$$

1	1	1
1	1	1
1	1	1

Linear filters: examples



Original

$$\frac{1}{9} \begin{bmatrix} 1 & 1 & 1 \\ 1 & 1 & 1 \\ 1 & 1 & 1 \end{bmatrix} =$$

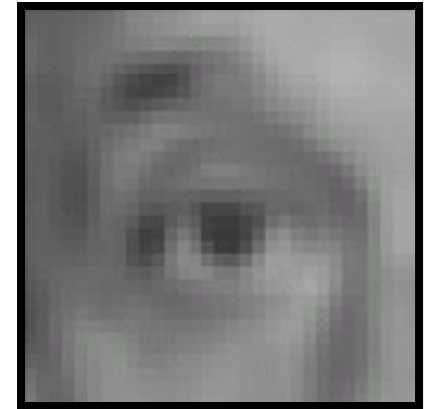

Blur (with a mean filter)

Practice with linear filters



Original

0	0	0
0	1	0
0	0	0

?

Practice with linear filters



Original

0	0	0
0	1	0
0	0	0



Filtered
(no change)

Practice with linear filters



Original

0	0	0
0	0	1
0	0	0

?

Practice with linear filters



Original

0	0	0
0	0	1
0	0	0



Shifted left
By 1 pixel

Back to the box filter

